

SmartLoop/PSTN



EN 54-2
EN 54-4
EN 54-21

0051
0051-CPR-1415
0051-CPR-1416
0051-CPR-1417
0051-CPR-1418
0051-CPR-1419
0051-CPR-1420

PSTN: LANDLINE DIGITAL AND VOICE DIALLER BOARD FOR SMARTLOOP CONTROL PANELS

SMARTLOOP

The SmartLoop/PSTN board allows the SmartLoop fire control panel to communicate over the landline (PSTN). It manages (and monitors) 2 lines and uses the most widely used reporting protocols (SIA, Contact ID, etc.). The two supervised phone lines guarantee signalling in the event of linedown faults. The board has an 8 slot audio memory for up to 8 voice-call messages. The board is completely managed by its microcontroller and is capable of generating a series of emergency calls in the event of a CPU fault on the control panel. It is also capable of generating a series of emergency calls in the event of an alarm during CPU fault status on the control panel (**Emergency54** technology).



MAIN FEATURES

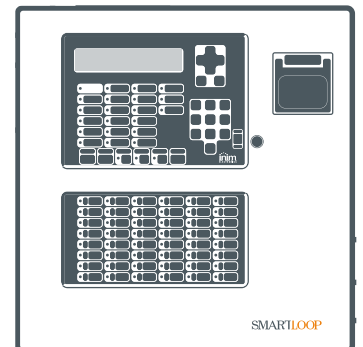

- Supported by SmartLoop control panels
- Permits the connection of 2 phone lines (main line + backup line)
- 1 board for each control panel
- Digital calls (SIA, CIS etc.)
- Voice calls
- 8 user-recordable messages of 10 seconds each
- Operating voltage 24 Vdc
- Current draw in stand by: 20 mA
- Current draw Max: 60 mA

INSTALLATION

The board comes with supports which screw into the motherboard.
The board plugs directly into the motherboard.

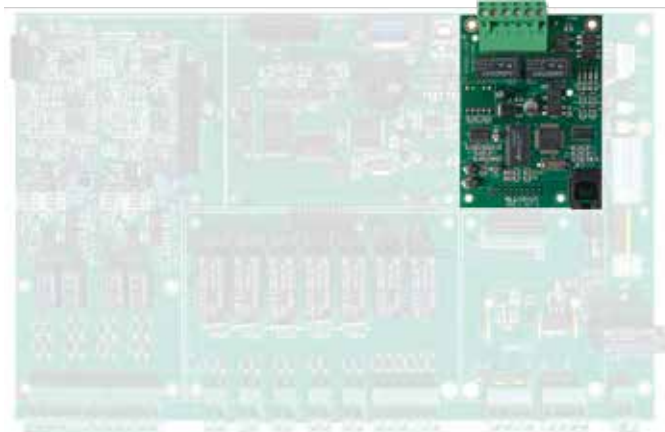

CONNECTIONS

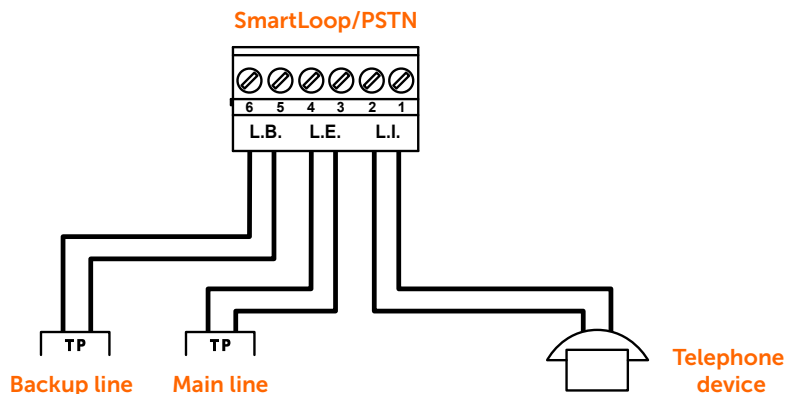

ORDER CODES

SmartLoop/2080-P: control panel with 2 loops expandable to 8, equipped with command keypad, display, status LEDs and housing for SmartLoop/PRN printer (accessory item)

SmartLoop/2080-G: control panel with 2 loops expandable to 8, equipped with command keypad and display

SmartLoop/2080-S: control panel with 2 loops expandable to 8, with unequipped flush front

SmartLoop/1010-P: control panel with 1 loop, non-expandable, equipped with command keypad, display, status LEDs and housing for SmartLoop/PRN printer (accessory item)

SmartLoop/1010-G: control panel with 1 loop, non-expandable, equipped with command keypad and display

SmartLoop/1010-S: control panel with 1 loop, non-expandable, with unequipped flush front

SmartLoop/PSTN: landline digital and voice dialler board